

GasMultiBloc®
Combined regulator and
safety shut-off valves
Two-stage function
Integrated bypass valve

DUNGS®
Combustion Controls

MB-ZRD(LE) 405 - 412 B07

7.25



Technical description

The DUNGS GasMultiBloc® integrates filter, regulator, valves and pressure switches in one compact fitting.

- Dirt trap: microfilter
- One regulator, two main valves and one bypass valve: B07
- Two single-stage valves, one two-stage valve
- Two valves are fast opening, one valve is slow opening
- Solenoid valves up to 360 mbar (36 kPa) as per DIN EN 161 Class A Group 2
- Sensitive setting of output pressure by proportional regulator as per DIN EN 88 Class A Group 2
- High flow rates with low pressure drop
- DC solenoid drive interference degree N
- Main volume restrictor at valve V2, bypass restrictor at valve V3
- Hydraulic opening delay
- Flange connections with pipe threads as per ISO 7/1
- Simple mounting
- Compact, light-weight

The modular system permits individual solutions by using an internal bypass valve in connection with separately controlled valves, by adding a valve proving system, mini/maxi pressure switches, pressure limiters, limit switches at valve V2.

Application

The modular system permits individual solutions in gas safety and regulator engineering. Suitable for gases of families 1, 2, 3 and other neutral gaseous media.

Approvals

EC type test approval as per EC Gas Appliance Directive:

MB-ZR...405-412 B07 CE-0085 AP 3156

EC type test approval as per EC Pressure Equipment Directive:

MB-ZR...405-412 B07 CE0036

Approvals in other important gas consuming countries.

Functional description of gas flow

1. When the valves V1 and V2 are closed, chamber A is under inlet pressure.
2. A hole D in the filter housing connects min. pressure switch with chamber A. If the inlet pressure applied to the pressure switch exceeds the incoming reference value, it switches through to the automatic burner control. After release by the automatic burner control, valves V1 and V3 open.
3. The gas flow through chambers A, B and via bypass valve V3 in C of the GasMulti-Bloc is released. The ignition gas volume is adjusted by using the bypass restrictor. The pressure regulator controls the pressure upstream of valves V2 and V3.
4. When valve V2 is released, the gas flows directly into chamber C, the bypass valve V3 remains open. On request, the second stage of valve V2 opens.

Operating method of valve-regulator combination on valve V1

A regulator, compensating for residual pressure is integrated in valve V1 (pressure regulating part). Armature V1 is not connected to the valve plate unit. When it opens, the armature pretensions the compression spring and releases the valve plate unit. When the valve closes, the armature acts directly on the valve plate unit. The output pressure upstream of valves V2 and V3 is defined by pretensioning the regulating spring 7 (tension spring) via setting screw 18. The output pressure acts via opening E on the working diaphragm of the regulator. In regulated state, setting spring inlet pressure and pressure of working diaphragm are in force equilibrium. The compensating diaphragm 23 ensures the fast closing function of valve V1 and a high regulating quality.

Operating method of bypass valve V3

The bypass valve V3 opens at the same time as valve V1. Ignition gas flow is set by using bypass restrictor 28.

Operating method of valve V2

The armature 14 of valve V2 is connected to the valve plate unit 12. When it opens, the armature 14 pretensions the compression spring 13. The maximum valve opening can be set by limiting the armature stroke by means of the main volume restrictor 20.

Min. opening (residual stroke) of Valve (0.5 to 1.0 mm)

The main volume restrictor 20 is set by rotating the adjusting plate or the hydraulic brake. When the second stage of valve 2 opens, compression spring 13 is continuously pretensioned. The maximum valve opening of the second stage can be set by limiting the armature stroke by means of the main volume restrictor. The main volume restrictor is set by rotating the adjusting plate or the hydraulic brake. The fast and/or slow opening characteristic is influenced by setting the fast stroke 21 at the hydraulic brake under the cover.

Closing function

When the supply voltage to the main valve solenoid coils is interrupted, the valves V1, V3 and V2 are closed within < 1 s by the compression springs.

Sectional drawing of MB-ZRD(LE)...B07

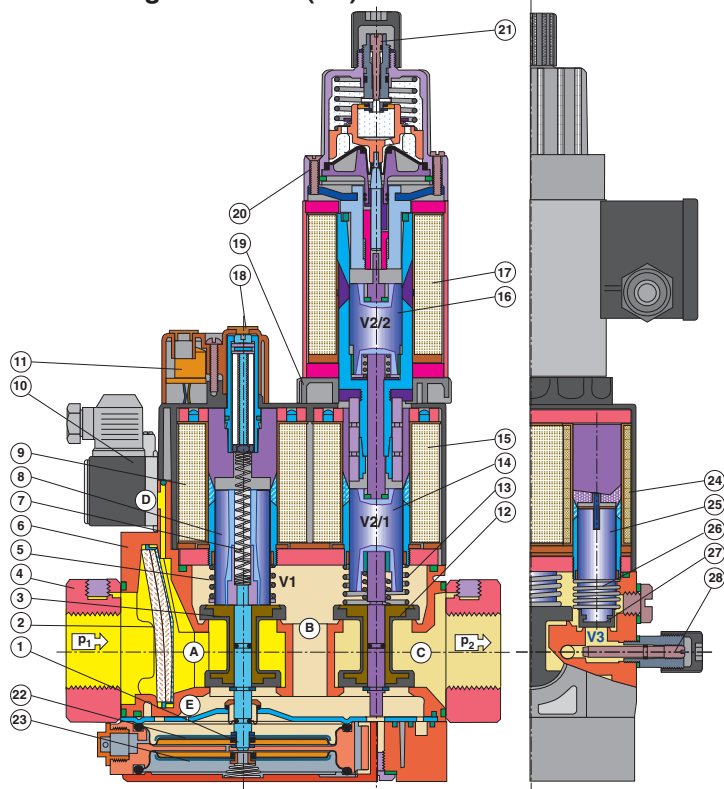

- | | | |
|-----------------------------------|--------------------------------|---------------------------|
| 1 Pressure regulator | 11 Electrical connection | 22 Working diaphragm |
| 2 Microfilter | 12 Valve V2 | 23 Compensation diaphragm |
| 3 Valve V1 | 13 Closing spring V2 | 24 Armature V3 |
| 4 Connection flange | 14 Armature V2 (1st stage) | 25 Solenoid V3 |
| 5 Closing spring V1 | 15 Solenoid V2 (1st stage) | 26 Closing spring V3 |
| 6 Housing | 16 Armature V2 (2nd stage) | 27 Valve V3 |
| 7 Regulating spring | 17 Armature V2 (2nd stage) | 28 Bypass restrictor |
| 8 Armature V1 | Setting: | |
| 9 Solenoid V1 | 18 - Gas pressure pa | |
| 10 Gas pressure switch (optional) | 19 - Partial volume, 1st stage | |
| | 20 - Main volume | |
| | 21 - Fast stroke | |

Pressure taps

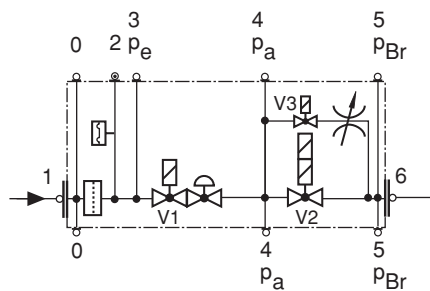

- | | |
|------------|-------------------------|
| 0 | Filter cover |
| 1, 3, 4, 6 | G 1/8 screw plug |
| 2 | Test nipple |
| 5 | M4 screwed sealing plug |

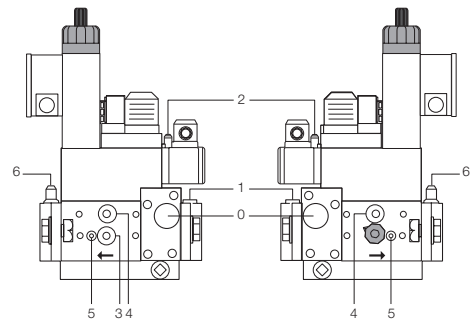

Electrical connection

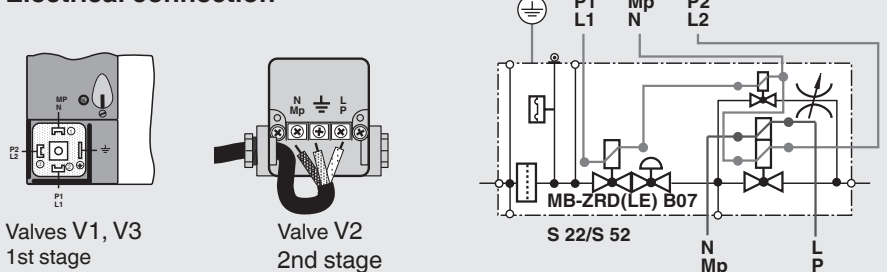

Valves V1, V3
1st stage

Valve V2
2nd stage

Specifications

Nominal diameters Flange with pipe threads as per ISO 7/1 (DIN 2999)	MB-...405/407 B07 Rp 1/2, 3/4 and their combinations	MB-...410/412 B07 Rp 3/4, 1, 1 1/4 and their combinations																				
Max. operating pressure	360 mbar (36 kPa)																					
Output pressure ranges	MB-... S22 p_a: 4 mbar (0.4 kPa) to 20 mbar (2 kPa) MB-... S52 p_a: 4 mbar (0.4 kPa) to 50 mbar (5 kPa)																					
Media	Gases of families 1, 2, 3 and other neutral gaseous media.																					
Ambient temperature	-15 °C to +70 °C (Do not operate MB-D below 0 °C in liquid gas systems. Only suitable for gaseous liquid gas, liquid hydrocarbons destroy sealing materials.)																					
Dirt trap	Sieve, microfilter, changing the filter is possible without removing the valve.																					
Pressure switches	Types GW A5, GW A2, NB A2, ÜB A2 mountable as per DIN EN 1854. For further information, refer to Datasheet GW A2 No. 215 183 and Datasheet GW A5 No. 225 901.																					
Pressure regulator	Pressure regulator compensated for residual pressure, leakproof seal when switched off by means of valve V1 as per DIN EN 88 Class A. Setpoint spring permanently installed (no spring exchange possible). A vent line above roof is not required. Internal pulse tap provided.																					
Solenoid valve V1	Valve as per DIN EN 161 Class A Group 2, fast closing, fast opening																					
Solenoid valve V2	Valve as per DIN EN 161 Class A Group 2, fast closing																					
	<table border="1"> <thead> <tr> <th></th> <th>Valve V2 design</th> <th>Main volume restrictor</th> <th>Partial volume restrictor</th> </tr> </thead> <tbody> <tr> <td>MB-ZR</td> <td>fast opening</td> <td>with</td> <td>without</td> </tr> <tr> <td>MB-ZRD</td> <td>fast opening</td> <td>with</td> <td>with</td> </tr> <tr> <td>MB-ZRDLE</td> <td>slow opening</td> <td>with</td> <td>with</td> </tr> <tr> <td>MB-ZRLE</td> <td>slow opening</td> <td>with</td> <td>without</td> </tr> </tbody> </table>		Valve V2 design	Main volume restrictor	Partial volume restrictor	MB-ZR	fast opening	with	without	MB-ZRD	fast opening	with	with	MB-ZRDLE	slow opening	with	with	MB-ZRLE	slow opening	with	without	
	Valve V2 design	Main volume restrictor	Partial volume restrictor																			
MB-ZR	fast opening	with	without																			
MB-ZRD	fast opening	with	with																			
MB-ZRDLE	slow opening	with	with																			
MB-ZRLE	slow opening	with	without																			
Solenoid valve V3 (bypass)	Valve as per DIN EN 161 Class A Group 2, with volume restrictor																					
Measuring/ignition gas connection	For G 1/8 as per DIN ISO 228, refer to Pressure taps on page 2																					
Burner pressure monitor p _{Br}	Connection downstream of valve V2, pressure switch mountable on adapter laterally																					
Voltage / Frequency	50-60 Hz 220-230 V AC, -15 % +10 % Other preferred voltages: 240 VAC, 110-120 VAC, 48 VDC, 24-28 VDC																					
Electrical connection	Plug connection as per DIN EN 175301-803 for valves and pressure switches																					
Rating/power consumption Switch-on duration Degree of protection Radio interference	Refer to Dimensions on page 5 100 % IP 54 as per IEC 529 (EN 60529) Interference degree N																					
Materials of gas conveying parts	Housing Diaphragms, seals Solenoid drive	aluminium die casting NBR basis, Silopren (silicone rubber) steel, brass, aluminium																				
Installation position	Solenoid vertically upright or lying horizontally as well as its intermediate positions.																					
Closed position signal contact	Closed position signal contact, type K01/1 (DIN-tested), mountable to V2																					

Equipment variants GasMultiBloc®...B07 Two-stage function	405 B07	407 B07	410 B07	412 B07	
MB-ZR	•	•	•	•	
MB-ZRD	•	•	•	•	
MB-ZRDLE	•	•	•	•	
MB-ZRLE	•	•	•	•	
Microfilter (standard) with sieve	•	•	•	•	
Gas pressure switch downstream of filter	•	•	•	•	
downstream of valve V2 on adapter	•	•	•	•	
Pressure regulator	•	•	•	•	
Valve V1, double seat	•	•	•	•	
Valve V2, single seat	•	—	•	—	
Valve V2, double seat	—	•	—	•	
Valve V3, single seat with restrictor	•	•	•	•	
Valve opening separately	•	•	•	•	S...2 version
Flange Rp 1/2	•	•	—	—	<ul style="list-style-type: none"> • = possible (•) = on request — = not possible
Flange Rp 3/4	•	•	•	•	
Flange Rp 1	—	—	•	•	
Flange Rp 1 1/4	—	—	•	•	

MB-...B07 version

- V1 = Valve 1
- V2 = Valve 2
- V3 = Valve 3
- 4 = Filter
- 5 = Pressure switch, optional
- 6 = Regulator

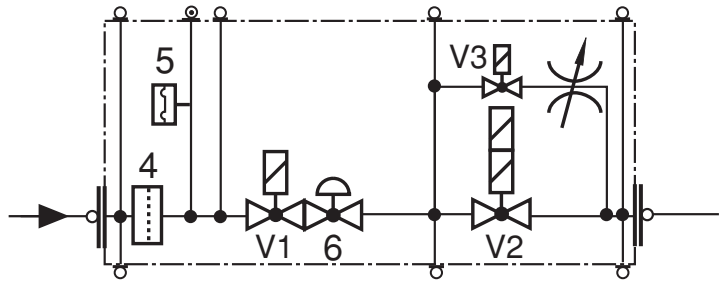

Mounting of VPS 504 valve proving system possible
 Mounting of K01/1 closed position signal contact possible

Type key of MultiBloc®



Dimensions [mm]

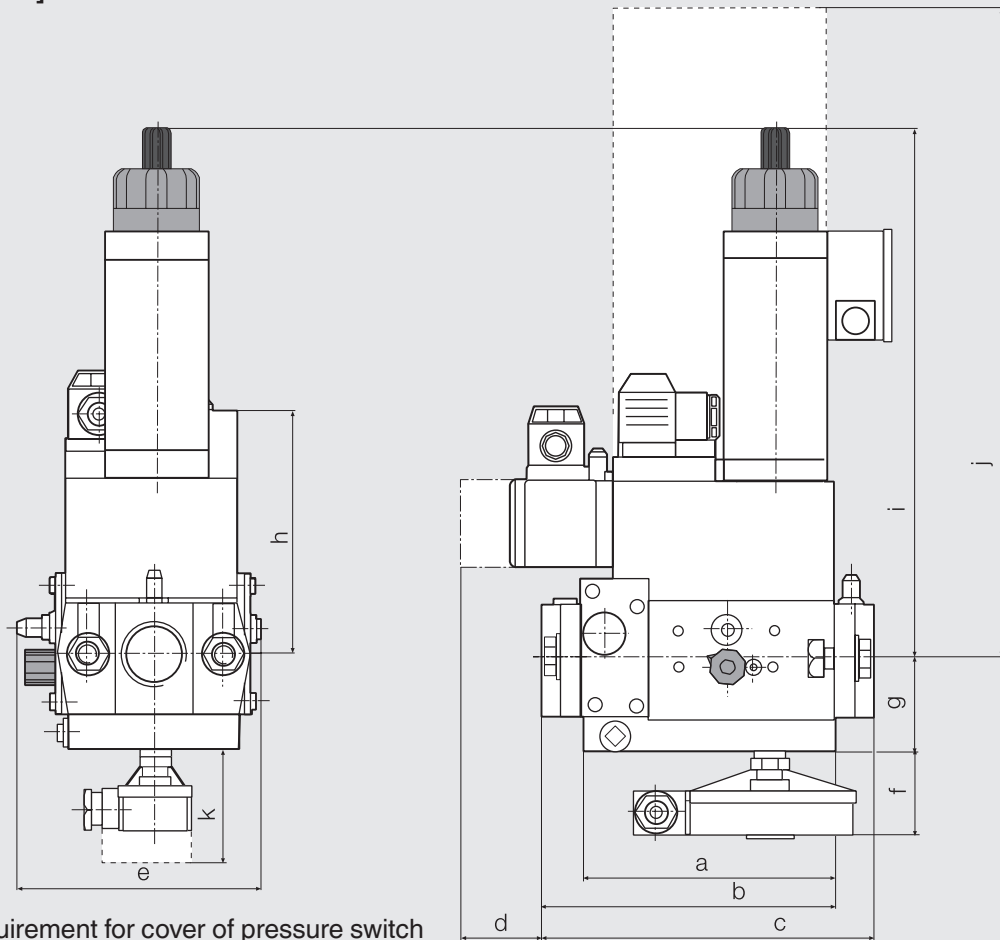

- d = Space requirement for cover of pressure switch
- j = Space requirement for exchanging the solenoid
- k = Space requirement for K01/1 closed position signal contact

Type	Nominal rating [VA]		Dimensions [mm]										Weight [kg]		
	230 V AC; +20 °C	S22	S52	a	b	c	d	e	f	g	h	i		j	k
MB-ZRD 405/407 B07	70	70		110	130.5	151	40	120	50	46	115	170	230	80	3.1
MB-ZRD(LE) 405/407 B07	70	70		110	130.5	151	40	120	50	46	115	210	230	80	3.2
MB-ZRD 410/412 B07	134	134		140	162.5	185	40	145	50	55	135	225	300	80	6.4
MB-ZRD(LE) 410/412 B07	134	134		140	162.5	185	40	145	50	55	135	260	300	80	6.5

Volumetric flow pressure loss characteristic via bypass valve V3, restrictor open

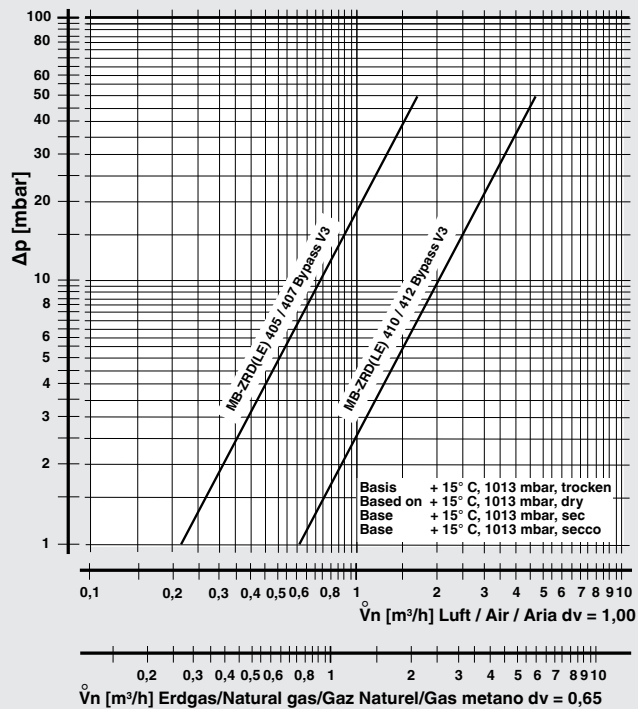

GasMultiBloc®
Combined regulator and
safety shut-off valves
Two-stage function
Integrated bypass valve

MB-ZRD(LE) 405 - 412 B07



Volumetric flow pressure loss characteristics in regulated state with microfilter

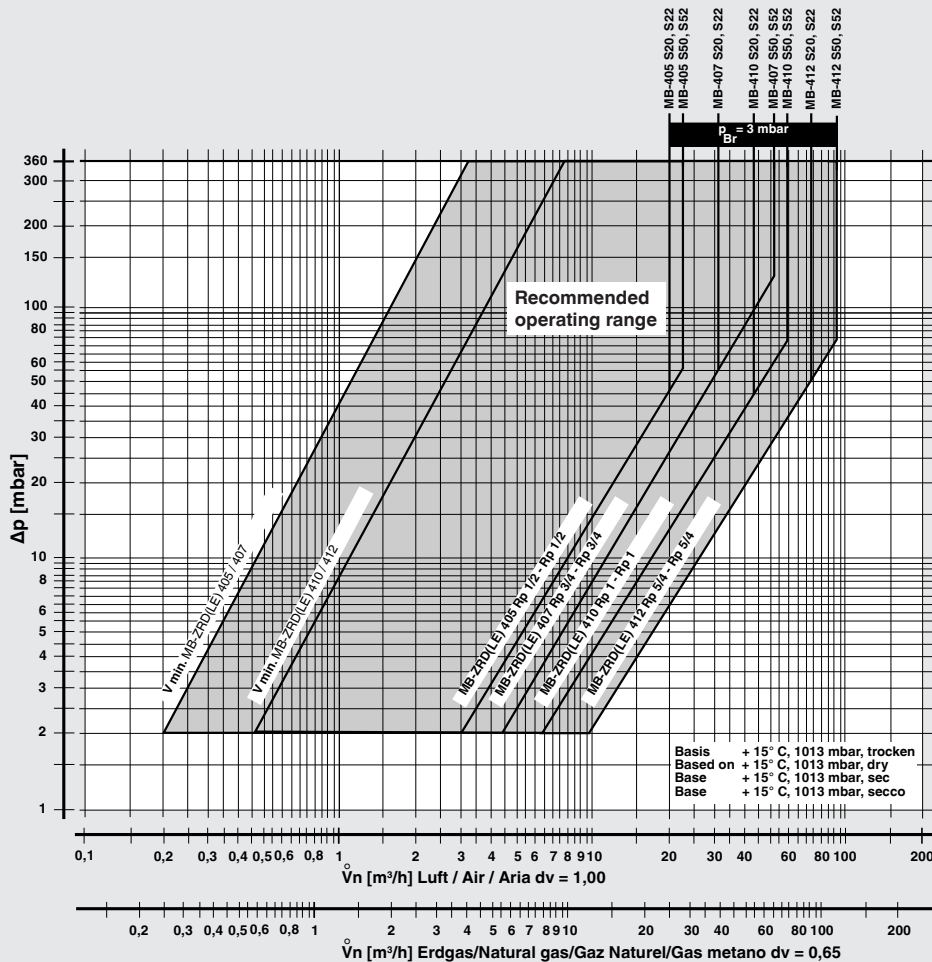

$$f = \sqrt{\frac{\text{Dichte Luft}}{\text{Dichte des verwendeten Gases}}}$$

Spec. weight air / poids spécifique de l'air / peso specifico aria

Spec. weight of gas used / poids spécifique du gaz utilisé / peso specifico del gas utilizzato

Gas type	Density [kg/m³]	dv	f
Nat. gas	0.81	0.65	1.24
City gas	0.58	0.47	1.46
LPG	2.08	1.67	0.77
Air	1.24	1.00	1.00

$$\dot{V}_{\text{verwendetes Gas/gas used/gaz utilizzato}} = \dot{V}_{\text{Luft/air/aria}} \times f$$

We reserve the right to make any changes in the interest of technical progress.

Head Offices and Factory
Karl Dungs GmbH & Co. KG
Siemensstraße 6-10
D-73660 Urbach, Germany
Telephone +49 (0)7181-804-0
Fax +49 (0)7181-804-166

Postal address
Karl Dungs GmbH & Co. KG
Postfach 12 29
D-73602 Schorndorf, Germany
e-mail info@dungs.com
Internet www.dungs.com